

- N.B. (1) Question No.1 is compulsory.
 (2) Attempt any three questions out of the remaining five questions.
 (3) Figures to right indicate full marks.

- Q1. (a) Evaluate $\int_c |z| dz$, where c is the left half of unit circle $|z|=1$ from $z=-i$ to $z=i$ 5
- (b) If λ is an Eigen value of the matrix A with corresponding Eigen vector X , prove that λ^n is an Eigen value of A^n with corresponding Eigen vector X . 5
- (c) Find the extremal of $\int_{x_1}^{x_2} \frac{\sqrt{1+y'^2}}{x} dx$ 5
- (d) Find the unit vector orthogonal to both $[1,1,0]$ & $[0,1,1]$ 5
- Q2. (a) Find the curve on which the functional $\int_0^1 [y'^2 + 12xy] dx$ with $y(0)=0$ & $y(1)=1$ can be Extremised. 6
- (b) Find the Eigen values and Eigen vectors for the matrix $\begin{bmatrix} 2 & 2 & 1 \\ 1 & 3 & 1 \\ 1 & 2 & 2 \end{bmatrix}$ 6
- (c) Obtain two distinct Laurent's series expansions of $f(z) = \frac{2z-3}{z^2-4z+3}$ in powers of $(z-4)$ indicating the region of convergence in each case 8
- Q3. (a) If $A = \begin{bmatrix} 2 & 1 \\ 1 & 2 \end{bmatrix}$, find A^{50} 6
- (b) Evaluate $\int_c \frac{\sin \pi z^2 + \cos \pi z^2}{(z-1)(z-2)} dz$, where c is the circle $|z|=3$ 6
- (c) Using Rayleigh-Ritz method, find an approximate solution for the extremal of the functional $I(y) = \int_0^1 (y'^2 - 2y - 2xy) dx$ subject to $y(0)=2$, $y(1)=1$. 8



Q4. (a) Find the vector orthogonal to both $[-6, 4, 2]$ & $[3, 1, 5]$ 6

(b) Show that the matrix $A = \begin{bmatrix} 7 & 4 & -1 \\ 4 & 7 & -1 \\ -4 & -4 & 4 \end{bmatrix}$ is derogatory 6

and find its minimal polynomial.

(c) Reduce the matrix of the quadratic form $6x_1^2 + 3x_2^2 + 3x_3^2 - 4x_1x_2 + 4x_1x_3 - 2x_2x_3$ to canonical form through congruent transformation and find its rank, signature, and value class. 8

Q5. (a) Find the extremal of $\int_{x_0}^{x_1} (2xy - y'^2) dx$ 6

(b) Show that the set $W = \{[x, y, z] \mid y = x + z\}$ is a subspace of \mathbf{R}^3 under the usual addition and scalar multiplication. 6

(c) Show that the following matrix $A = \begin{bmatrix} 6 & -2 & 2 \\ -2 & 3 & -1 \\ 2 & -1 & 3 \end{bmatrix}$ is diagonalisable. Also find the diagonal form and a diagonalising matrix. 8

Q6. (a) If $f(a) = \int_c \frac{3z^2 + 7z + 1}{z - a} dz$, where c is a circle $|z| = 2$, find the values of

i) $f(-3)$, ii) $f(i)$, iii) $f'(1-i)$ 6

(b) Evaluate $\int_0^{2\pi} \frac{d\theta}{13 + 5\sin\theta}$ 6

(c) Verify Cayley-Hamilton theorem for the matrix A and hence find A^{-1} and A^4 . 8

$$\text{Where } A = \begin{bmatrix} 1 & 2 & -2 \\ -1 & 3 & 0 \\ 0 & -2 & 1 \end{bmatrix}$$

JP-Con. : 10054-15.



S.E. (Sem IV) (CBSGS) - ELEX

Sub: Microprocessor & Peripherals.

QP Code : 3528

- N.B. : 1. Question no. 1 is compulsory
2. Solve any three from the remaining five questions.
3. Assume suitable additional data if necessary.

- Q1. a) What is stack? Explain the use and operation of stack and stack pointer? (5marks)
b) What is an instruction queue? Explain? (5 marks)
c) Explain the flag register of 8085 microprocessor? (5 marks)
d) Explain the LOCK(bar) & TEST(bar) Signal? (5marks)

Q2. a) Design a 8086 based system with following specifications

- CPU at 10MHz in minimum mode operation
- 64 KB SRAM using 8 KB devices
- 16 KB EPROM using 4 KB devices
- One 8255 PPI for keyboard interface

Design system with absolute decoding. Clearly show memory address map and I/O address map. Draw a neat schematic for chip selection logic. (20 Marks)

Q3. a) Explain the first five dedicated interrupts of 8086? (10marks)

b) Explain with one example addressing modes of 8086 ? (10marks)

Q.4. a) Write 8086 assembly language program to move a string of words from offset 1000h to offset 6000h. The Length of the string is 0Ch. (10marks)

b) Explain the following directives

CODE , ASSUME , ALINE , EQU , EVEN , Various Data & Model directives (10 marks)

Q5. a) What are different multiprocessor configurations? Explain Closely Coupled Configuration? (10marks)

b) Sketch and explain the interface of PPI 8255 to the 8086 microprocessor in minimum mode. Interface four 7 segment LEDs to display as a BCD counter (10 marks)

Q6. Write Short Note on

- a) Difference between a JMP instruction and CALL instruction. (5marks)
b) Flag register of 8086. (5marks)
c) Operation modes of 8237 DMA Controller (5marks)
d) Procedure of interfacing 8259 with CPU (5marks)



JP-Con. 10877-15.

QP Code : 3531

(3 Hours)

[Total Marks : 80

- N. B. : (1) Question No. 1 is compulsory.
(2) Attempt any three questions from remaining questions.
(3) Assume suitable data if necessary.

1. Attempt any four :-

20

- Explain the effect of addition of pole and zero to the system.
- Define gain margin and phase margin. Explain how these margins are used for stability analysis.
- Differentiate open-loop and closed-loop systems.
- Explain need of compensator.
- State and prove properties of state transition matrix.

2. (a) Obtain the transfer function of the following electrical system.

10

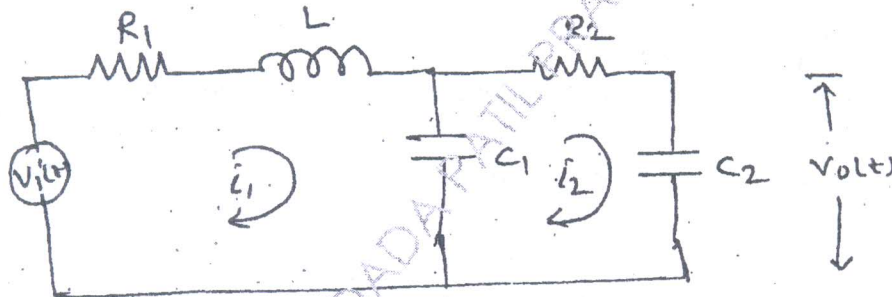

(b) Find the transfer function $\frac{c(s)}{R(s)}$ for the following system using block diagram reduction technique.

10

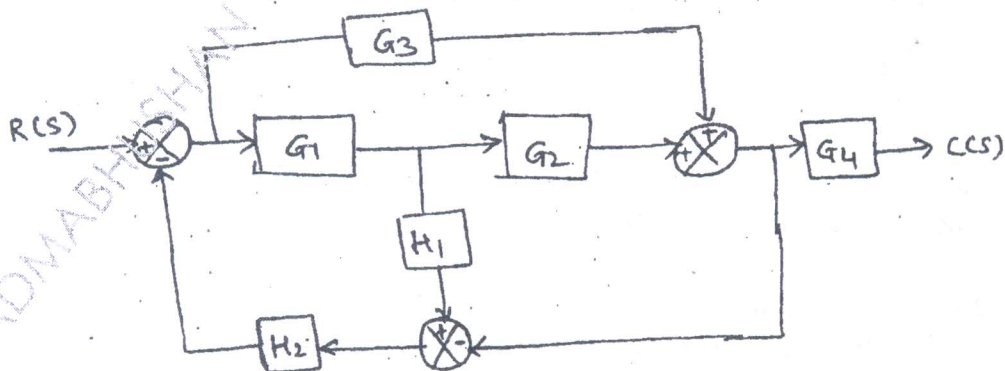

[TURN OVER

3. (a) Obtain the state space model for the following mechanical system 10

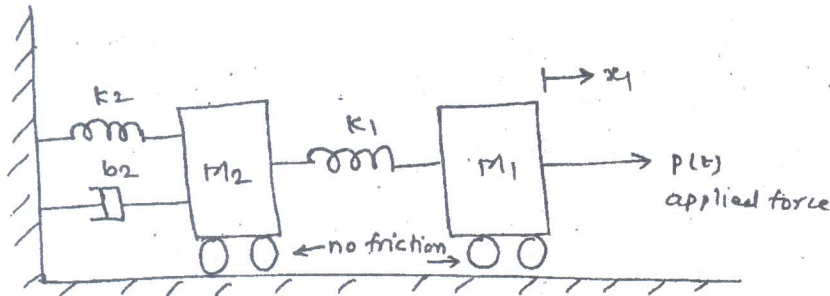

- (b) Obtain the solution of the system described by 10

$$\dot{x} = \begin{bmatrix} 0 & 1 \\ -2 & -4 \end{bmatrix} x + \begin{bmatrix} 0 \\ 2 \end{bmatrix} u$$

4. (a) The open-loop transfer function of a unity feedback system is given by 10

$$G(s) = \frac{K}{(s+3)(s+5)(s^2+2s+2)}$$

Plot the root loci. Find the points where the root loci cross the imaginary axis

- (b) Construct the bode plot for the following transfer function. Comment on stability 10

$$G(s) = \frac{100}{s^2(1+0.005s)(1+0.08s)(1+0.5s)}$$

5. (a) Check controllability and observability for the system described by 10

$$\dot{x} = \begin{bmatrix} 0 & 6 & -5 \\ 1 & 0 & 2 \\ 3 & 2 & 4 \end{bmatrix} x + \begin{bmatrix} 0 \\ 1 \\ 2 \end{bmatrix} u$$

$$y = [1 \quad 2 \quad 3]x$$

- (b) Derive the relationship between time and frequency domain specifications of the system.

6. (a) Write a short note on model predictive control 5
 (b) Explain the features of P, I and D control actions 5
 (c) Find the range of K for the system to be stable 5
 $s^4 + 7s^3 + 10s^2 + 2ks + k = 0$
 (d) Describe the Mason's gain formula with an example. 5

QP Code : 3534

(3 Hours)

[Total Marks : 80

- N. B. : (1) Question No. 1 is compulsory.
(2) Attempt any three questions from the remaining five questions.
(3) Assume suitable data if required.

1. Answer the following (any four) :- 20
(a) Classify and explain the various noises that affect communication.
(b) DSB-FC (AM) is a wastage of power and bandwidth. Justify.
(c) Derive the expression for frequency modulated wave.
(d) What are pre-emphasis and de-emphasis.
(e) Explain companding and its need in communication.
2. (a) Explain basic block diagram of communication system in detail. 6
(b) Explain the following terms 8
(i) Signal to noise ratio
(ii) Noise factor
(iii) Noise figure
(iv) Equivalent noise temperature
(c) Write short note on vestigial sideband transmission. 6
3. (a) Explain with the help of circuit diagram and waveforms any one method of FM-generation. 10
(b) Comment on bandwidth of FM wave. 4
(c) An AM broadcast transmitter has a carrier power output of 100 kw. Find the total power and sideband power with 75% modulation. 6
4. (a) The maximum deviation allowed in an FM broadcast system is 75KHz. If the modulating signal is a single tone sinusoidal signal of 20 KHz, find the band width of FM signal using carson's rule. What will be the change in band width if modulating signal frequency is doubled? Determine the bandwidth when modulating signal amplitude is doubled. 10
(b) Draw the block diagram of Adaptive delta modulation system and explain its operation. What are the advantages of this over delta modulation/ 10
5. (a) Explain frequency demodulation system using phase discriminator. Draw the circuit diagram and phasor diagram. 10
(b) Explain in detail generation and detection of PPM. 10

[TURN OVER

JP-Con. 12400-15.

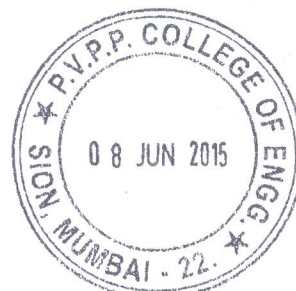

6. Write short notes on any four of the following :-

20

- (a) Electromagnetic frequency spectrum
 - (b) Frequency division multiplexing
 - (c) Sampling theorem
 - (d) Automatic Gain Control.
 - (e) Image Frequency Rejection.
-



12-6-15

QP Code : 3537

(3 Hours)

[Total Marks : 60]

- N.B. (1) Question no. 1 is compulsory
 (2) Solve any **three** out of remaining **five** questions.
 (3) **Figures to the right indicate full marks.**
 (4) **Assume suitable data if necessary.**

1. Solve any **three**:- 15
- (a) What is the difficulty in starting a dc motor without starter.
 (b) A 6 pole, 3-phase induction motor is connected to 50Hz Supply. If it is running at 970 rpm. Find the slip.
 (c) What is the principle of operation of shaded pole induction motor.
 (d) What is the basic operating principle of d.c. stepping motors.
 (e) State the types of synchronous motor.
2. (a) Explain the different methods of controlling speed of 8
 (i) DC shunt motor (ii) DC series motor. 7
 (b) A 4-pole, 500V shunt motor has 720 wave connected conductors in the armature. The full load armature current is 60A and the flux per pole is .03 wb. The armature resistance is 0.2Ω and the contact drop is 1V per brush. Calculate the full load speed of the motor.
3. (a) Obtain the expression for full load torque of 3-ph. induction motor. Also obtain the conduction for maximum torque under running condition and at starting 8
 (b) Write a short note on star-delta starter used for 3ph. induction motor 7
4. (a) A 4 pole, 250w, 115 V, 60Hz capacitor. start induction motor takes a full load line current of 5.3A while running at 1760rpm. If the full load efficiency of the motor is 64%. find 8
 (i) Motor slip (ii) Power factor (iii) Full load torque
 (b) What is the difference between the capacitor start motor and the capacitor start capacitor run induction motor. 7
5. (a) Explain construction and operation of variable reluctance stepper motor. 8
 (b) Classify unipolar brushless DC motor. and explain in detail unipolar brushless D.C. motor. 7
6. Write a short note on:- 15
- (a) Autotransformer starter for 3 phase induction motor.
 (b) Draw and explain three point starter used for d.c. shunt motor.
 (c) Explain the blocked rotor test for single phase induction motor.

JP-Con. 12652-15.

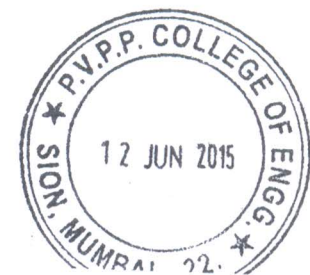

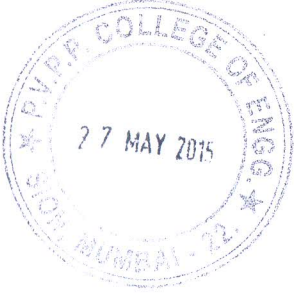

S.E. (Sem-IV) (OLD) - Elec

Sub = Electronic Circuit Analysis & Design
(OLD COURSE)

QP Code : 4039

(3 Hours)

[Total Marks :100

- N.B. : (1) Question No. 1 is compulsory.
(2) Solve any four questions from remaining questions.
(3) Assume suitable data if necessary.

1. (a) Design two stage JFET based CS Amplifier for $AV \geq 500$, $V_o = 3V$ use suitable biasing circuit. 15
- (b) From the designed circuit calculate R_i , R_o and A_v . 5
2. (a) Which components affect high frequency response of JFET amplifier and hence derive equation of higher cut off frequency of JFET amplifier. 10
- (b) State the properties of crystal and hence explain different types of crystal oscillators, also state the different applications of it. 10
3. (a) For the given circuit find : 10

- (i) r_e (ii) $A_{vmid} \frac{V_o}{V_i}$ (iii) Lower cut off frequency

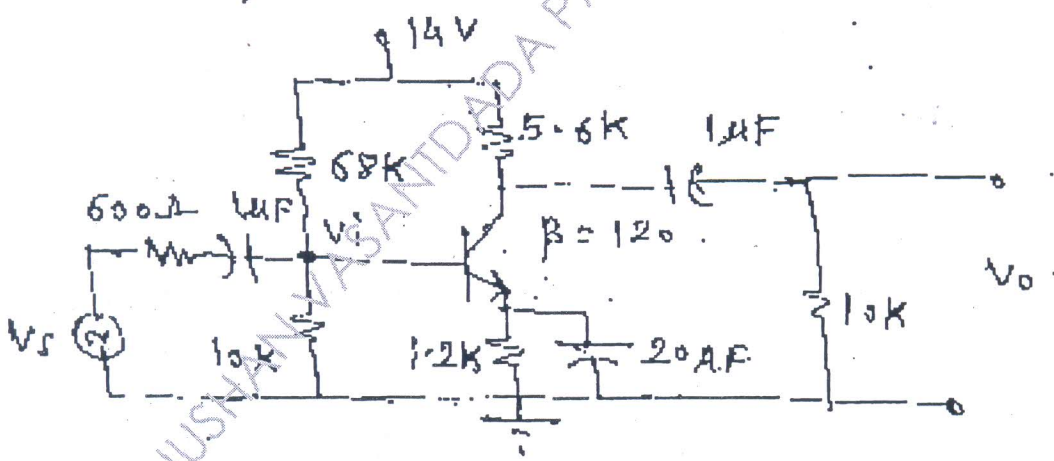

- (b) Design RC phase shift oscillator to generate frequency of 20KHz. 10
4. (a) What are the advantages of -ve feedback amplifiers, give the topologies of different -ve feedback amplifiers. 10
- (b) Design class B power amplifier to give output of 15W for 8Ω load. 10



QP Code : 4039

2

5. (a) Compare power amplifier with voltage amplifier and derive equation of efficiency of direct coupled series fed class A power amplifier. 10
- (b) What do you mean by CMRR, how it can be improved in differential amplifier. 10
6. (a) Derive equation of R_{iF} , R_{oF} and A_F for voltage shunt type -ve feedback amplifier. 10
- (b) For the given differential amplifier determine : 10
- (i) I_{CQ} (ii) V_{CEQ} (iii) A_{CM} (iv) A_{dm} (v) CMRR.

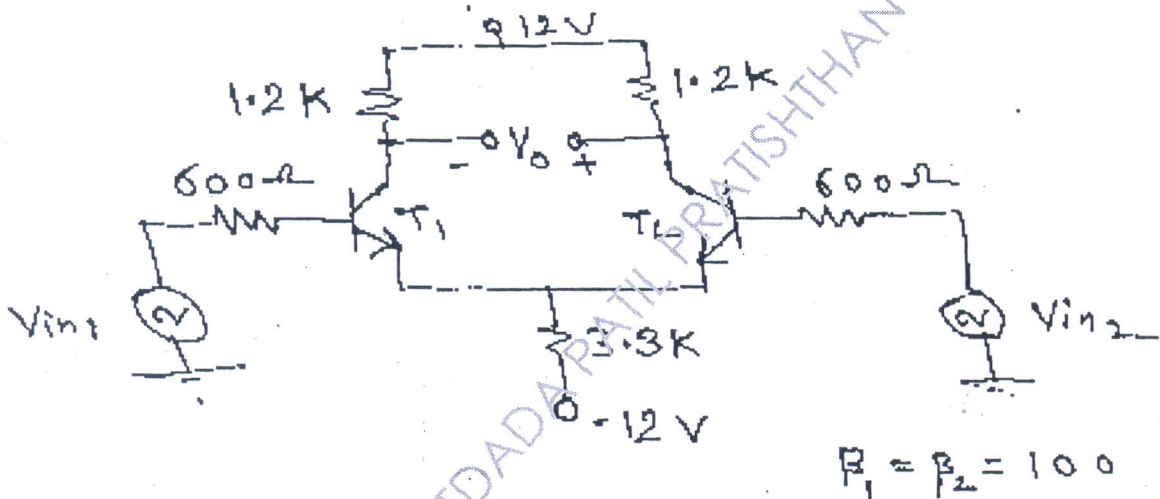

7. Write short notes on any four. 20
- (a) CASCODE Amplifier
- (b) Types of power Amplifiers
- (c) Differential Amplifiers
- (d) Characteristics of -ve feedback Amplifier
- (e) Clapp oscillator.

